

BPT BOX

Caja con ventilador centrífugo baja presión, de doble aspiración a transmisión
 Noise isolated cabinet fan
 Caisson de ventilation insonorisé à ventilateur centrifuge basse pression
 Lüftungsbox



Caja de ventilación completa, compuesta de ventilador anclado sobre soportes antivibratorios, motor fijado sobre bancada regulable, poleas y correas dimensionadas acorde a las prestaciones, aislamiento interno y junta elástica entre boca ventilador y boca impulsión de la caja.

Aplicaciones: Grandes instalaciones de climatización y ventilación.

With double inlet wheel. Composed of fan on antivibration mounting, motor, belts and pulley upon required working point.

Applications: Extract or intake of large airflow with high pressure for shopping centres, hospitals, airports, public places.

Caisson de ventilation composé d'un ventilateur ancré sur un support anti-vibration. Moteur fixé sur socle réglable, dimension des poulies et courroies adaptés aux prestations. Isolation thermo acoustique. Jonction élastique entre caisson et bouche de ventilation interne.

Applications: Convient aux installations nécessitant de fort débit et pression en extraction ou insufflation. Grandes installations de ventilation: centres commerciaux, aéroport, centres hospitaliers.

Preisgünstige Ventilatoreinheit mit Motor und Keilriemenantrieb. Mit Laufrad und Gehäuse aus verzinktem Stahlblech.

Anwendungen: Lüftung und Klima, für große Luftmengen, auch bei langen Rohrsystemen oder auch für höhere Widerstände in Maschinen und Aggregaten.

CARACTERÍSTICAS / CHARACTERISTICS / CARACTERISTIQUES / EIGENSCHAFTEN

- Caja de chapa galvanizada, aislada interiormente mediante panel ignífugo clase M1.
 - Rodete, álabes hacia delante, en chapa galvanizada.
 - Motores con aislamiento clase F y protección IP55.
- OPCIONES:
- Previa consulta pueden servirse para tensiones, frecuencias, regímenes de vueltas distintas y/o motores de doble velocidad.
- Casing of galvanised metal sheet. Insulation panel fire resist class M1.
 - Forward curved wheel of galvanised metal sheet.
 - Motor class F, protection IP55.
- OPTIONS:
- Different tensions, speed and frequencies, 2 speed motors.
- Caisson en tôle d'acier galvanisée équipé de panneaux thermo acoustique de classe M1 (ignifugé).
 - Turbine, aubes vers l'avant, en tôle galvanisée.
 - Moteurs avec isolation classe F et protection IP55.
- OPTIONS:
- Plusieurs fréquences, tensions et régimes de rotation. Moteur 2 vitesses.
- Gehäuse aus verzinktem Stahlblech. Isolierung aus feuerfestem Panel Klasse M1.
 - Vorwärtsgekrümmtes Radiallaufrad aus verzinktem Stahlblech.
 - Motor Feuchtraumausführung, Schutzart IP55.
- AUF ANFRAGE:
- Sonderspannungen oder -frequenzen, andere Umdrehungen oder 2-stufige Motoren.

		Pulgadas Inches Pouces Zoll	A	HP (kW)	ACCESORIOS / ACCESSORIES ACCESSOIRES / ZUBEHÖR			
					BPTE	FI	VA/VI	VS
BPT BOX 7-7/4T 0,18kW	BPTB001	7-7	0,80	1/4 (0,18)	•	•	•	•
BPT BOX 7-7/4T 0,25kW	BPTB002	7-7	1,10	1/3 (0,25)	•	•	•	•
BPT BOX 7-7/4T 0,37kW	BPTB003	7-7	1,30	1/2 (0,37)	•	•	•	•
BPT BOX 7-7/4T 0,55kW	BPTB004	7-7	1,60	3/4 (0,55)	•	•	•	•
BPT BOX 9-9/4T 0,37kW	BPTB005	9-9	1,30	1/2 (0,37)	•	•	•	•
BPT BOX 9-9/4T 0,55kW	BPTB006	9-9	1,60	3/4 (0,55)	•	•	•	•
BPT BOX 9-9/4T 0,75kW	BPTB007	9-9	2,20	1,00 (0,75)	•	•	•	•
BPT BOX 9-9/4T 1,1kW	BPTB008	9-9	2,90	1,50 (1,10)	•	•	•	•
BPT BOX 10-10/4T 0,37kW	BPTB009	10-10	1,30	1/2 (0,37)	•	•	•	•
BPT BOX 10-10/4T 0,55kW	BPTB010	10-10	1,60	3/4 (0,55)	•	•	•	•
BPT BOX 10-10/4T 0,75kW	BPTB011	10-10	2,20	1,00 (0,75)	•	•	•	•
BPT BOX 10-10/4T 1,1kW	BPTB012	10-10	2,90	1,50 (1,10)	•	•	•	•
BPT BOX 10-10/4T 1,5kW	BPTB013	10-10	3,65	2,00 (1,50)	•	•	•	•
BPT BOX 12-12/4T 0,37kW	BPTB014	12-12	1,30	1/2 (0,37)	•	•	•	•
BPT BOX 12-12/4T 0,55kW	BPTB015	12-12	1,60	3/4 (0,55)	•	•	•	•
BPT BOX 12-12/4T 0,75kW	BPTB016	12-12	2,20	1,00 (0,75)	•	•	•	•
BPT BOX 12-12/4T 1,1kW	BPTB017	12-12	2,90	1,50 (1,10)	•	•	•	•
BPT BOX 12-12/4T 1,5kW	BPTB018	12-12	3,65	2,00 (1,50)	•	•	•	•
BPT BOX 12-12/4T 2,2kW	BPTB019	12-12	5,05	3,00 (2,20)	•	•	•	•
BPT BOX 15-15/4T 0,55kW	BPTB020	15-15	1,60	3/4 (0,55)	•	•	•	•
BPT BOX 15-15/4T 0,75kW	BPTB021	15-15	2,20	1,00 (0,75)	•	•	•	•
BPT BOX 15-15/4T 1,1kW	BPTB022	15-15	2,90	1,50 (1,10)	•	•	•	•
BPT BOX 15-15/4T 1,5kW	BPTB023	15-15	3,65	2,00 (1,50)	•	•	•	•
BPT BOX 15-15/4T 2,2kW	BPTB024	15-15	5,05	3,00 (2,20)	•	•	•	•
BPT BOX 15-15/4T 3kW	BPTB025	15-15	6,60	4,00 (3,00)	•	•	•	•

ACCESORIOS / ACCESSORIES / ACCESSOIRES / ZUBEHÖR

■ **Accesorios equipos / Accessories equipments**
Accessoires équipements / Zubehör Wärmetauschereinheiten



BPTE (pg. 551)



FI (pg. 552)



VA (pg. 553)



VI (pg. 554)



VS (pg. 555)

		Pulgadas Inches Pouces Zoll	A	HP (kW)	ACCESORIOS / ACCESSORIES ACCESSOIRES / ZUBEHÖR			
					BPTE	FI	VA/VI	VS
BPT BOX 18-18/4T 0,75kW	BPTB026	18-18	2,20	1,00 (0,75)	•	•	•	•
BPT BOX 18-18/4T 1,1kW	BPTB027	18-18	2,90	1,50 (1,10)	•	•	•	•
BPT BOX 18-18/4T 1,5kW	BPTB028	18-18	3,65	2,00 (1,50)	•	•	•	•
BPT BOX 18-18/4T 2,2kW	BPTB029	18-18	5,05	3,00 (2,20)	•	•	•	•
BPT BOX 18-18/4T 3kW	BPTB030	18-18	6,60	4,00 (3,00)	•	•	•	•
BPT BOX 18-18/4T 4kW	BPTB031	18-18	9,40	5,50 (4,00)	•	•	•	•
BPT BOX 18-18/4T 5,5kW	BPTB032	18-18	12,14	7,50 (5,50)	•	•	•	•
BPT BOX 20-20/4T 1,5kW	BPTB033	20-20	3,65	2,00 (1,50)	•	•	•	•
BPT BOX 20-20/4T 2,2kW	BPTB034	20-20	5,05	3,00 (2,20)	•	•	•	•
BPT BOX 20-20/4T 3kW	BPTB035	20-20	6,60	4,00 (3,00)	•	•	•	•
BPT BOX 20-20/4T 4kW	BPTB036	20-20	9,40	5,50 (4,00)	•	•	•	•
BPT BOX 20-20/4T 5,5kW	BPTB037	20-20	12,14	7,50 (5,50)	•	•	•	•
BPT BOX 20-20/4T 7,5kW	BPTB038	20-20	16,90	10,00 (7,50)	•	•	•	•
BPT BOX 22-22/4T 3kW	BPTB040	22-22	6,60	4,00 (3,00)	•	•	•	•
BPT BOX 22-22/4T 4kW	BPTB041	22-22	9,40	5,50 (4,00)	•	•	•	•
BPT BOX 22-22/4T 5,5kW	BPTB042	22-22	12,14	7,50 (5,50)	•	•	•	•
BPT BOX 22-22/4T 7,5kW	BPTB043	22-22	16,90	10,00 (7,50)	•	•	•	•
BPT BOX 22-22/4T 9,2kW	BPTB044	22-22	17,85	12,50 (9,20)	•	•	•	•
BPT BOX 22-22/4T 11kW	BPTB045	22-22	22,60	15,00 (11,00)	•	•	•	•
BPT BOX 25-25/4T 2,2kW	BPTB046	25-25	5,05	3,00 (2,20)	•	•	•	•
BPT BOX 25-25/4T 3kW	BPTB047	25-25	6,60	4,00 (3,00)	•	•	•	•
BPT BOX 25-25/4T 4kW	BPTB048	25-25	9,40	5,50 (4,00)	•	•	•	•
BPT BOX 25-25/4T 5,5kW	BPTB049	25-25	12,14	7,50 (5,50)	•	•	•	•
BPT BOX 25-25/4T 7,5kW	BPTB050	25-25	16,90	10,00 (7,50)	•	•	•	•
BPT BOX 25-25/4T 9,2kW	BPTB051	25-25	17,85	12,50 (9,20)	•	•	•	•
BPT BOX 25-25/4T 11kW	BPTB052	25-25	22,60	15,00 (11,00)	•	•	•	•
BPT BOX 30-28/4T 4kW	BPTB053	30-28	9,40	5,50 (4,00)	•	•	•	•
BPT BOX 30-28/4T 5,5kW	BPTB054	30-28	12,14	7,50 (5,50)	•	•	•	•
BPT BOX 30-28/4T 7,5kW	BPTB055	30-28	16,90	10,00 (7,50)	•	•	•	•
BPT BOX 30-28/4T 9,2kW	BPTB056	30-28	17,85	12,50 (9,20)	•	•	•	•
BPT BOX 30-28/4T 11kW	BPTB057	30-28	22,60	15,00 (11,00)	•	•	•	•
BPT BOX 30-28/4T 15kW	BPTB058	30-28	31,00	20,00 (15,00)	•	•	•	•

DIMENSIONES / DIMENSIONS / DIMENSIONS / ABMESSUNGEN (mm)

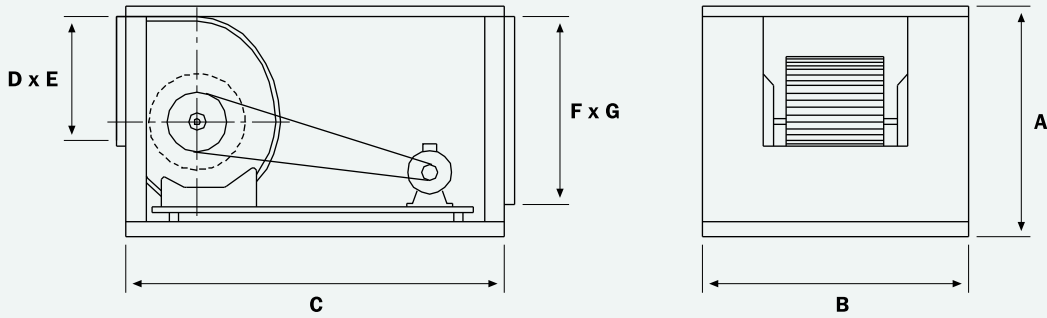

G/E = Altura / Height / Hauteur / Höhe
 F/D = Base / Wide / Largeur / Breite

	A	B	C	D x E	F x G	H	Kg ¹
BPT BOX 7-7	430	500	625	258 x 324	378 x 349	30	45
BPT BOX 9-9	460	550	700	328 x 288	408 x 400	30	55
BPT BOX 10-10	515	600	750	354 x 316	463 x 449	30	70
BPT BOX 12-12	595	700	850	416 x 369	543 x 549	30	90
BPT BOX 15-15	695	850	1.000	499 x 428	643 x 609	30	110
BPT BOX 18-18	825	1.000	1.172	570 x 504	773 x 649	30	150
BPT BOX 20-20	1.162	1.098	1.409	608 x 618	1.005 x 832	30	285
BPT BOX 22-22	1.347	1.189	1.568	608 x 712	1.096 x 1.019	30	315
BPT BOX 25-25	1.500	1.325	1.703	702 x 801	1.232 x 1.089	30	355
BPT BOX 30-28	1.695	1.523	1.936	893 x 941	1.429 x 1.185	30	480

¹ Versión con motor más potente
 Versión with powerful motor
 Version avec moteurs plus puissants
 Ausführung mit stärkerem Motor

ACCESORIOS / ACCESSORIES / ACCESSOIRES / ZUBEHÖR

■ **Accesorios equipos / Accessories equipments**
Accessoires équipements / Zubehör Wärmetauschereinheiten



BPT (pg. 551) **FI** (pg. 552) **VA** (pg. 553) **VI** (pg. 554) **VS** (pg. 555)

CURVAS CARACTERÍSTICAS / PERFORMANCE DATA / COURBES / KENNLINIEN

BPT / BPT BOX / TWIN BPT BOX 7-7

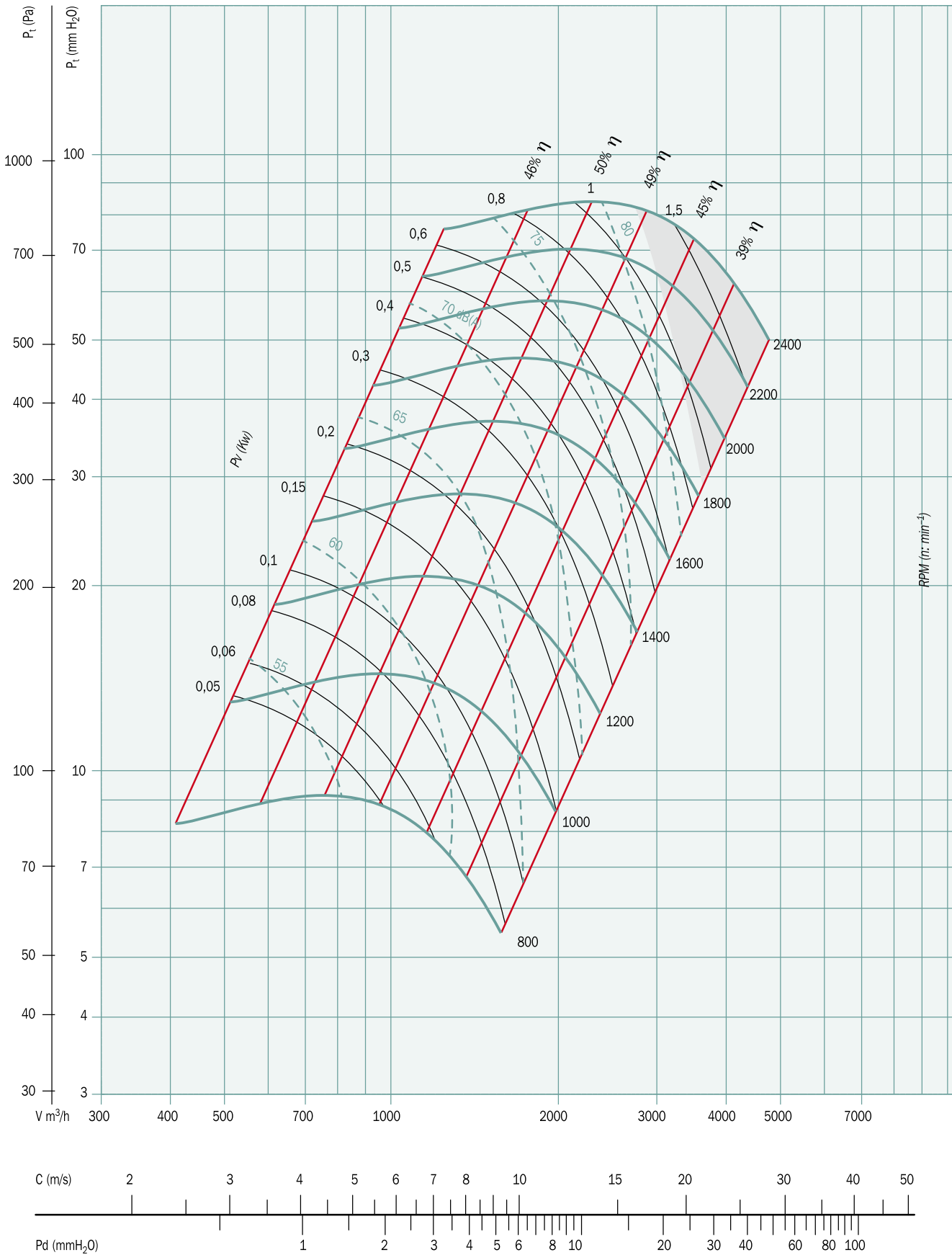

CURVAS CARACTERÍSTICAS / PERFORMANCE DATA / COURBES / KENNLINIEN

BPT / BPT BOX / TWIN BPT BOX / BPT BOX HT / BPT BOX HT COMPACT 9-9

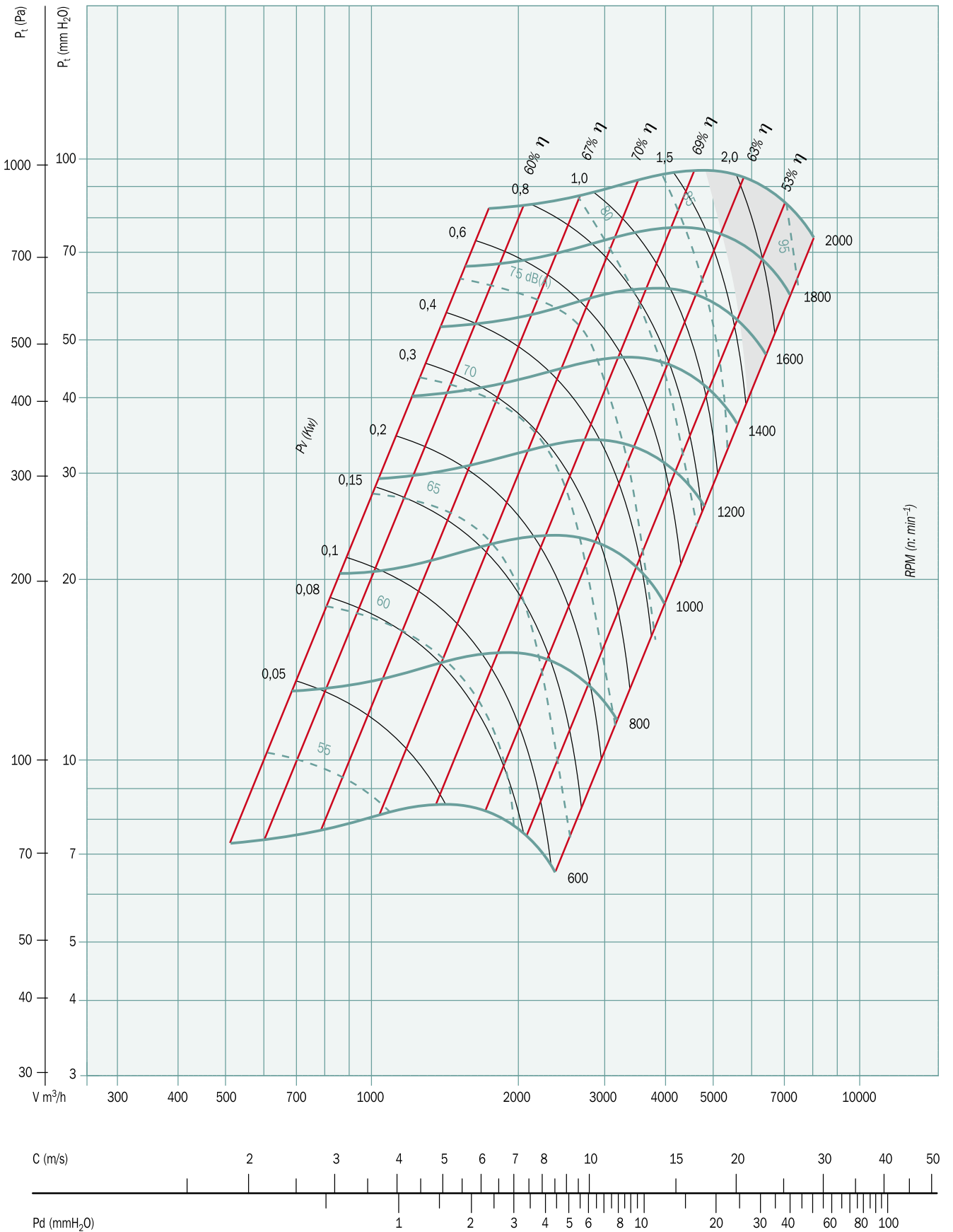

CURVAS CARACTERÍSTICAS / PERFORMANCE DATA / COURBES / KENNLINIEN

BPT / BPT BOX / TWIN BPT BOX / BPT BOX HT / BPT BOX HT COMPACT 10-10

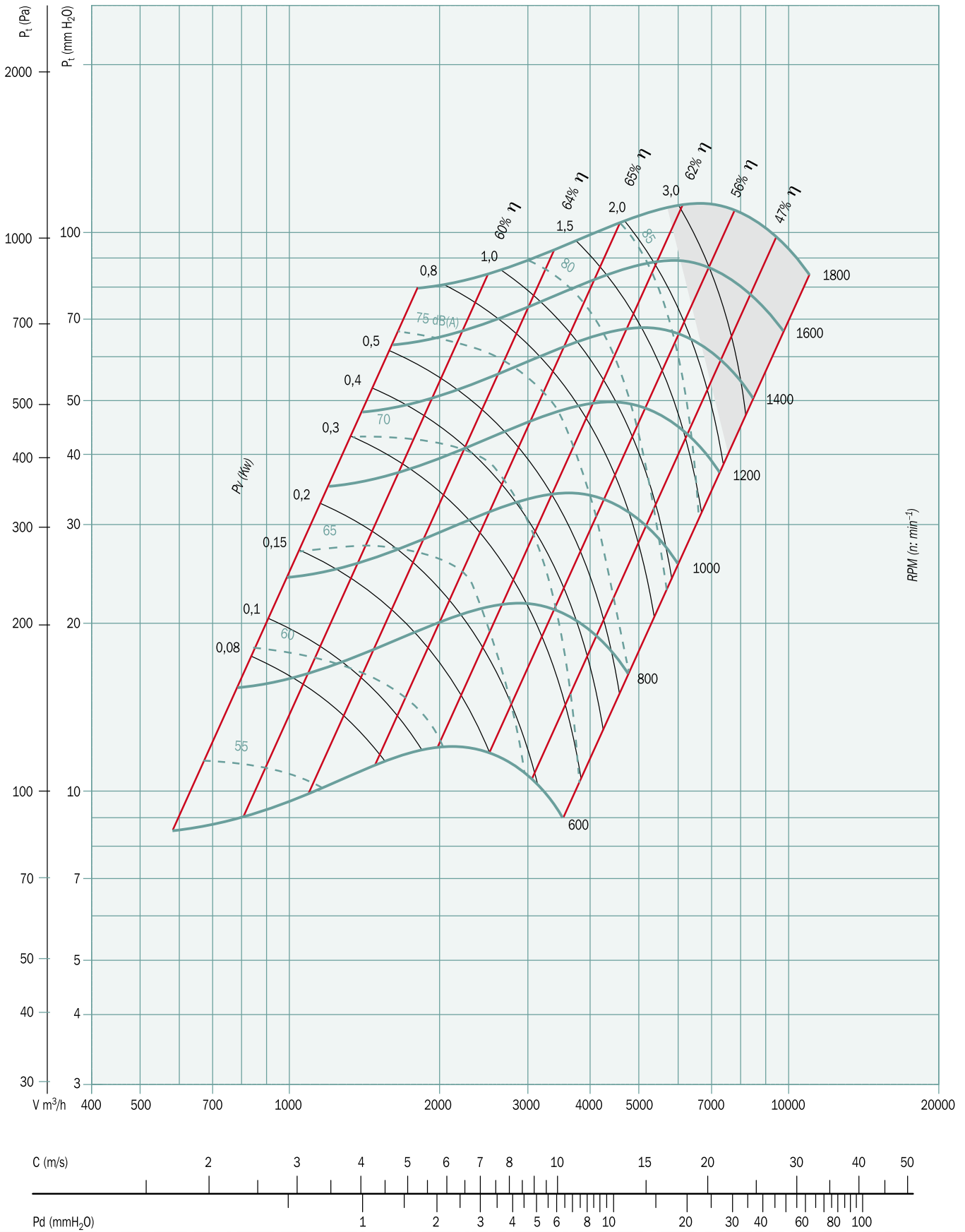

CURVAS CARACTERÍSTICAS / PERFORMANCE DATA / COURBES / KENNLINIEN

BPT / BPT BOX / TWIN BPT BOX / BPT BOX HT / BPT BOX HT COMPACT 12-12

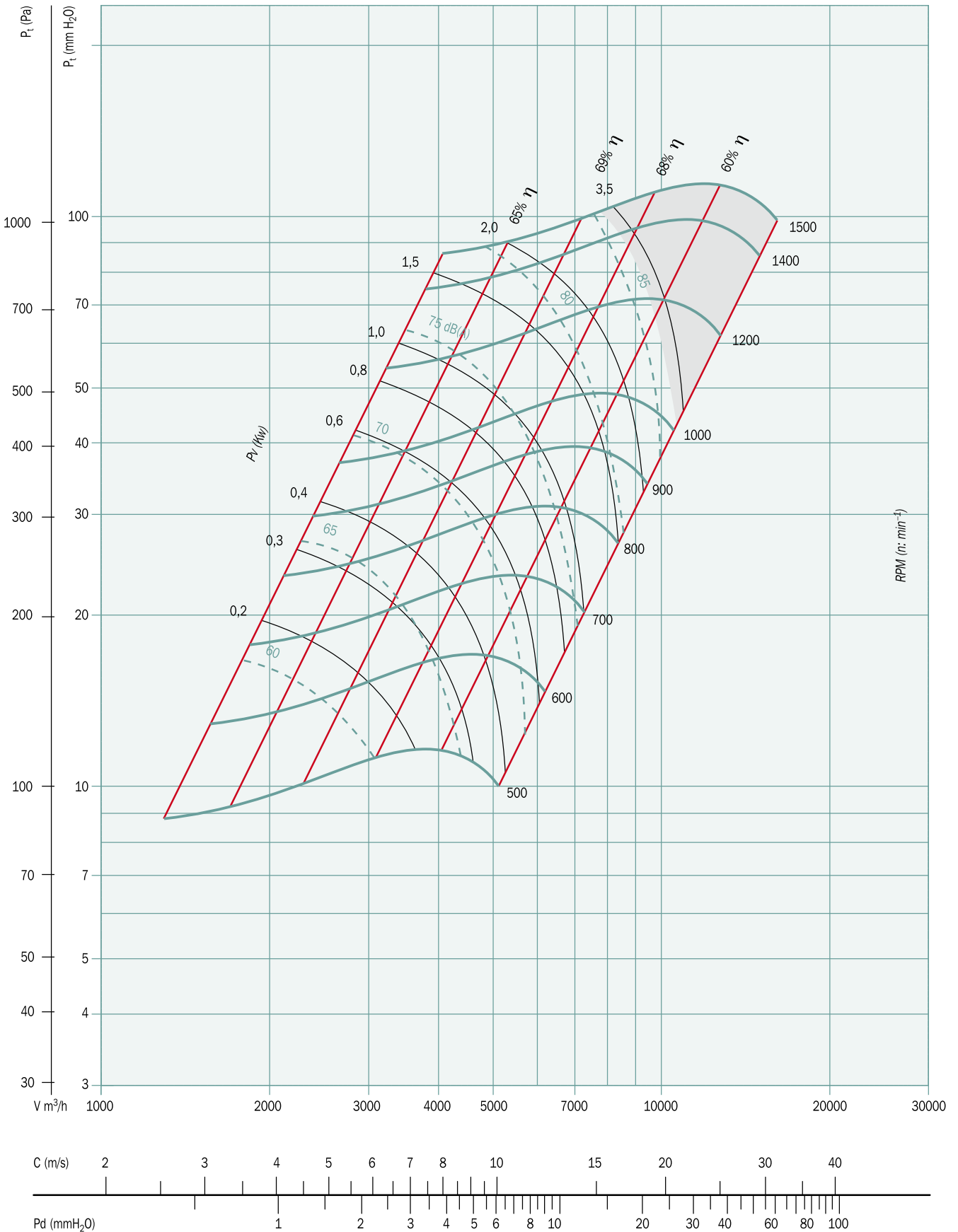

CURVAS CARACTERÍSTICAS / PERFORMANCE DATA / COURBES / KENNLINIEN

BPT / BPT BOX / TWIN BPT BOX / BPT BOX HT / BPT BOX HT COMPACT 15-15

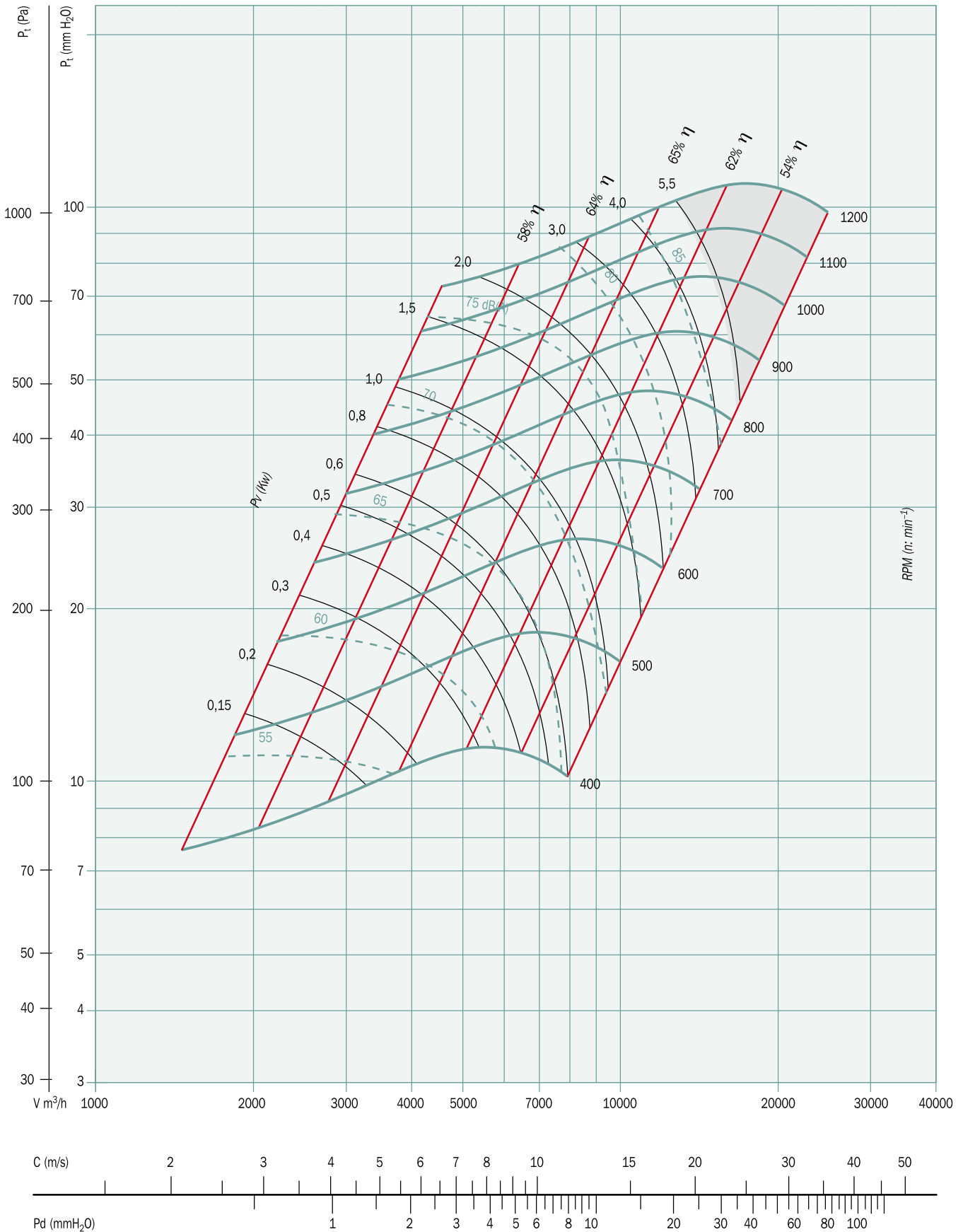

CURVAS CARACTERÍSTICAS / PERFORMANCE DATA / COURBES / KENNLINIEN

BPT / BPT BOX / TWIN BPT BOX / BPT BOX HT / BPT BOX HT COMPACT 18-18

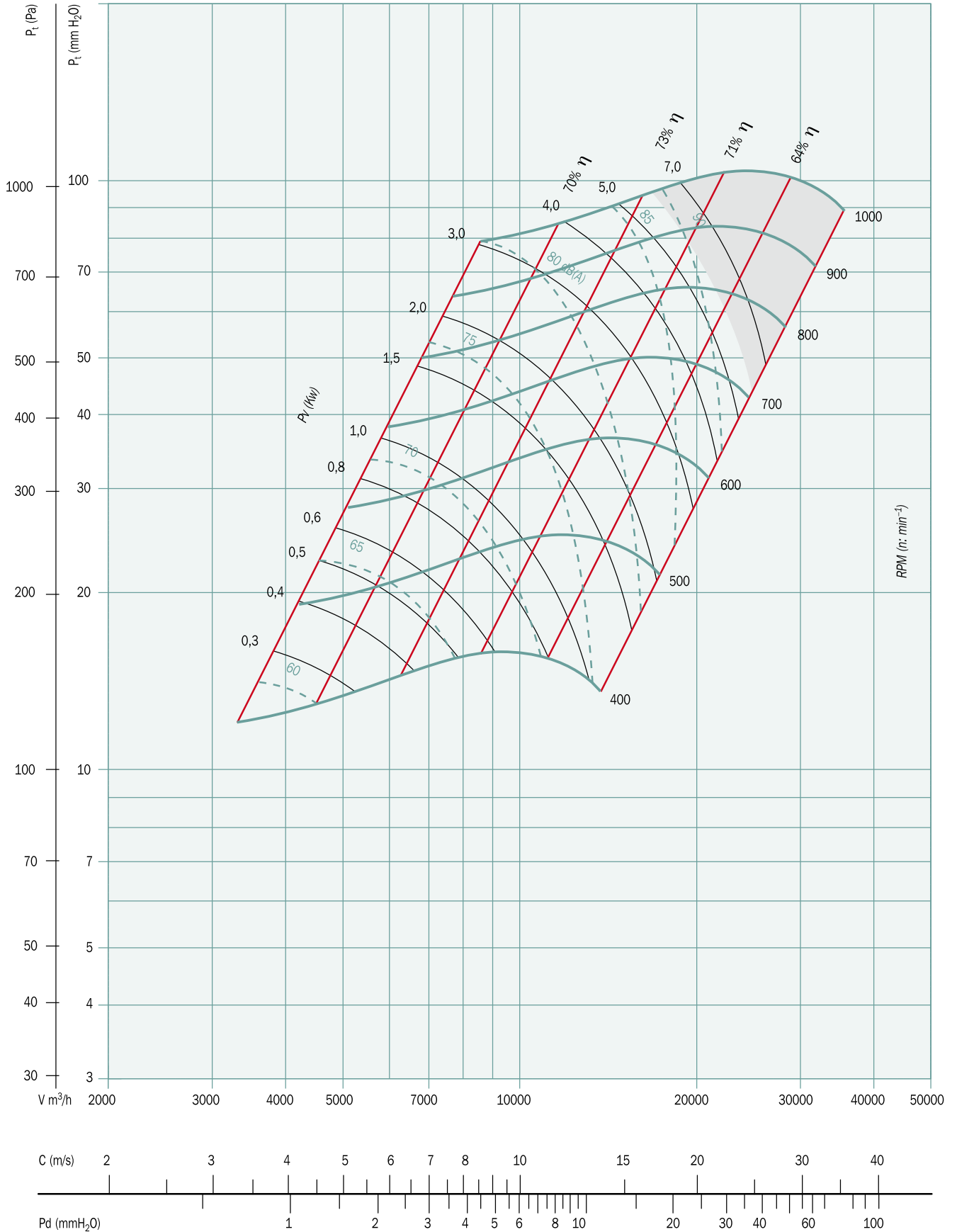

CURVAS CARACTERÍSTICAS / PERFORMANCE DATA / COURBES / KENNLINIEN

BPT / BPT BOX / BPT BOX HT / BPT BOX HT COMPACT 20-20

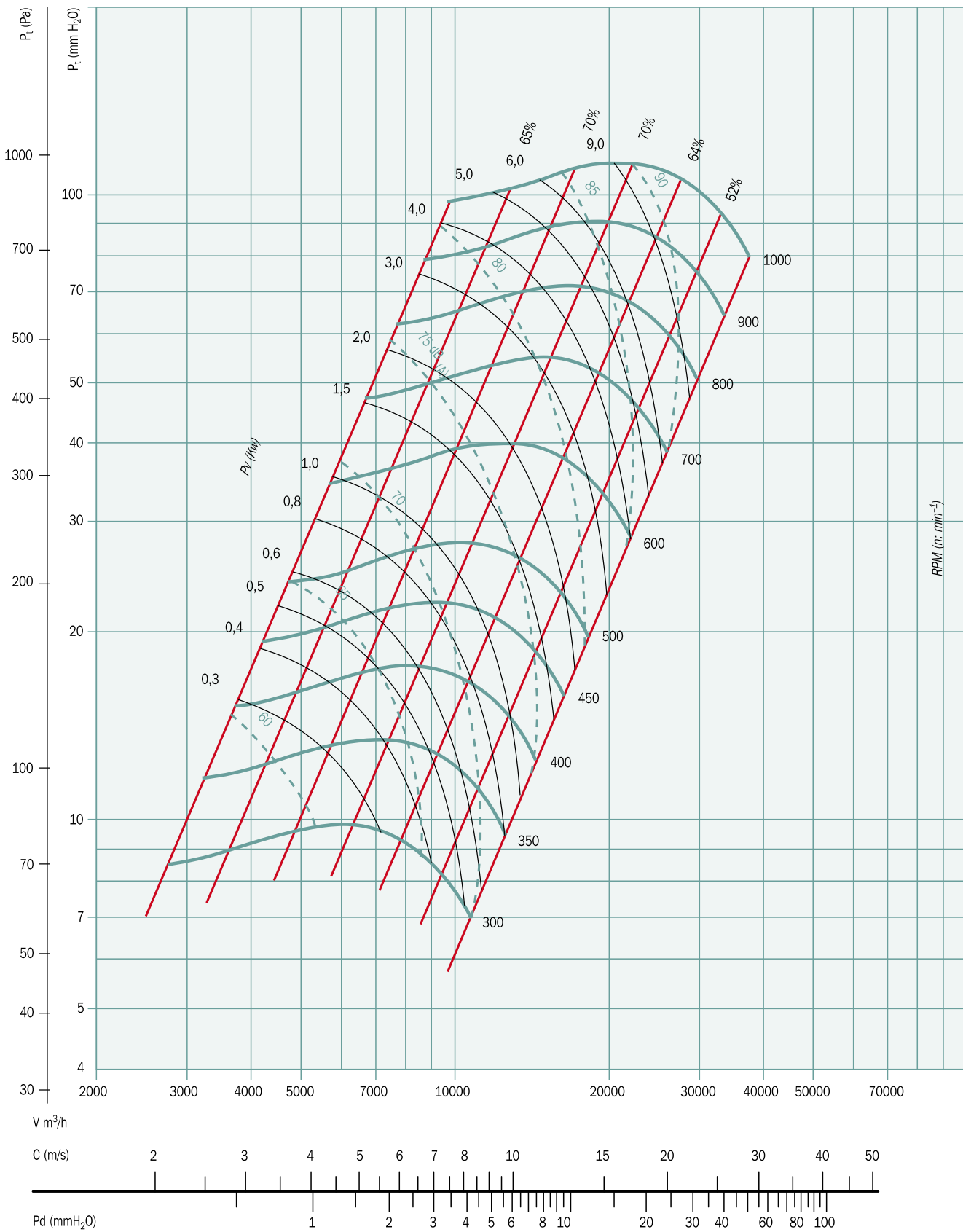

CURVAS CARACTERÍSTICAS / PERFORMANCE DATA / COURBES / KENNLINIEN

BPT / BPT BOX / BPT BOX HT / BPT BOX HT COMPACT 22-22

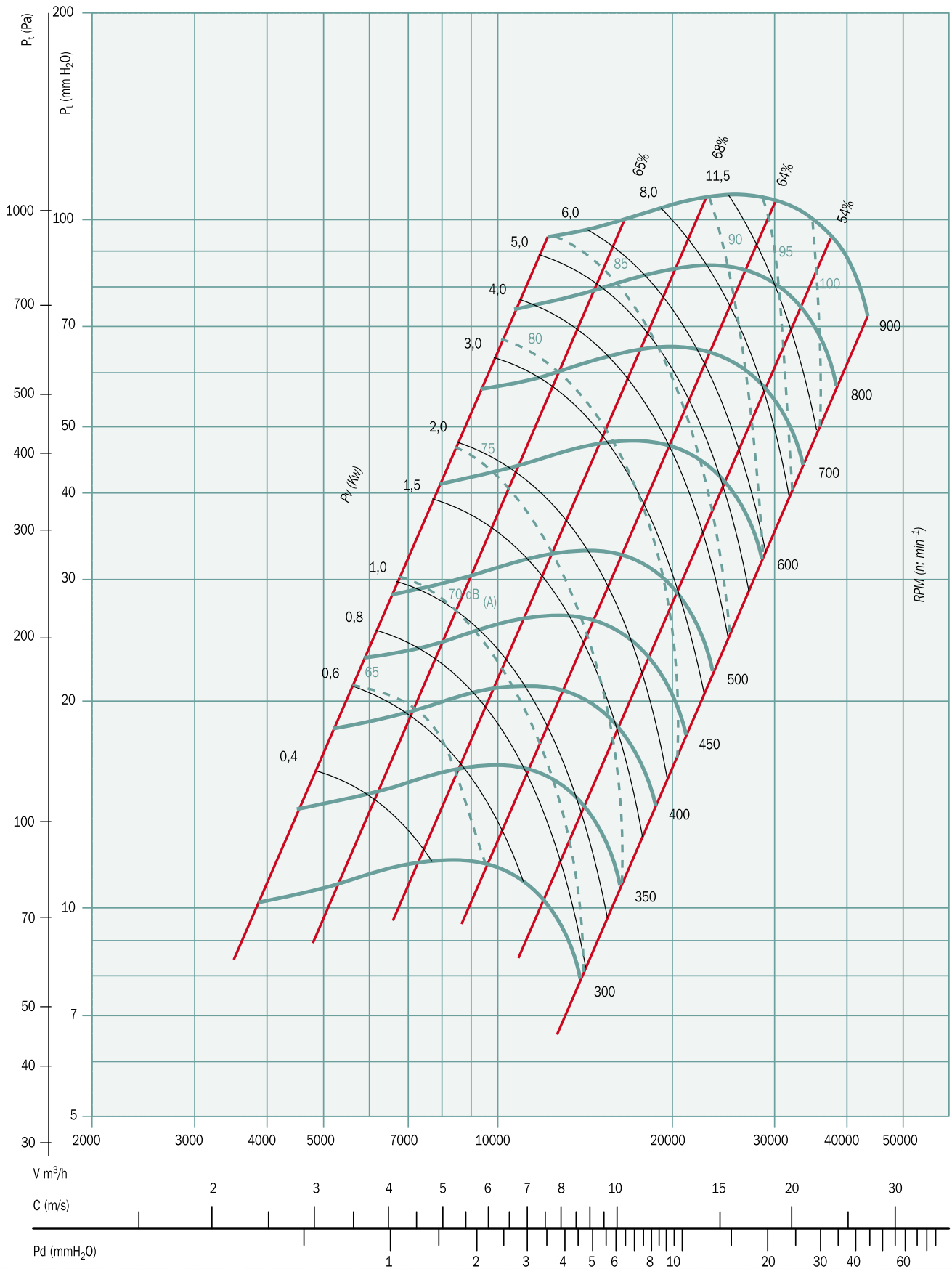

CURVAS CARACTERÍSTICAS / PERFORMANCE DATA / COURBES / KENNLINIEN

BPT / BPT BOX / BPT BOX HT / BPT BOX HT COMPACT 25-25

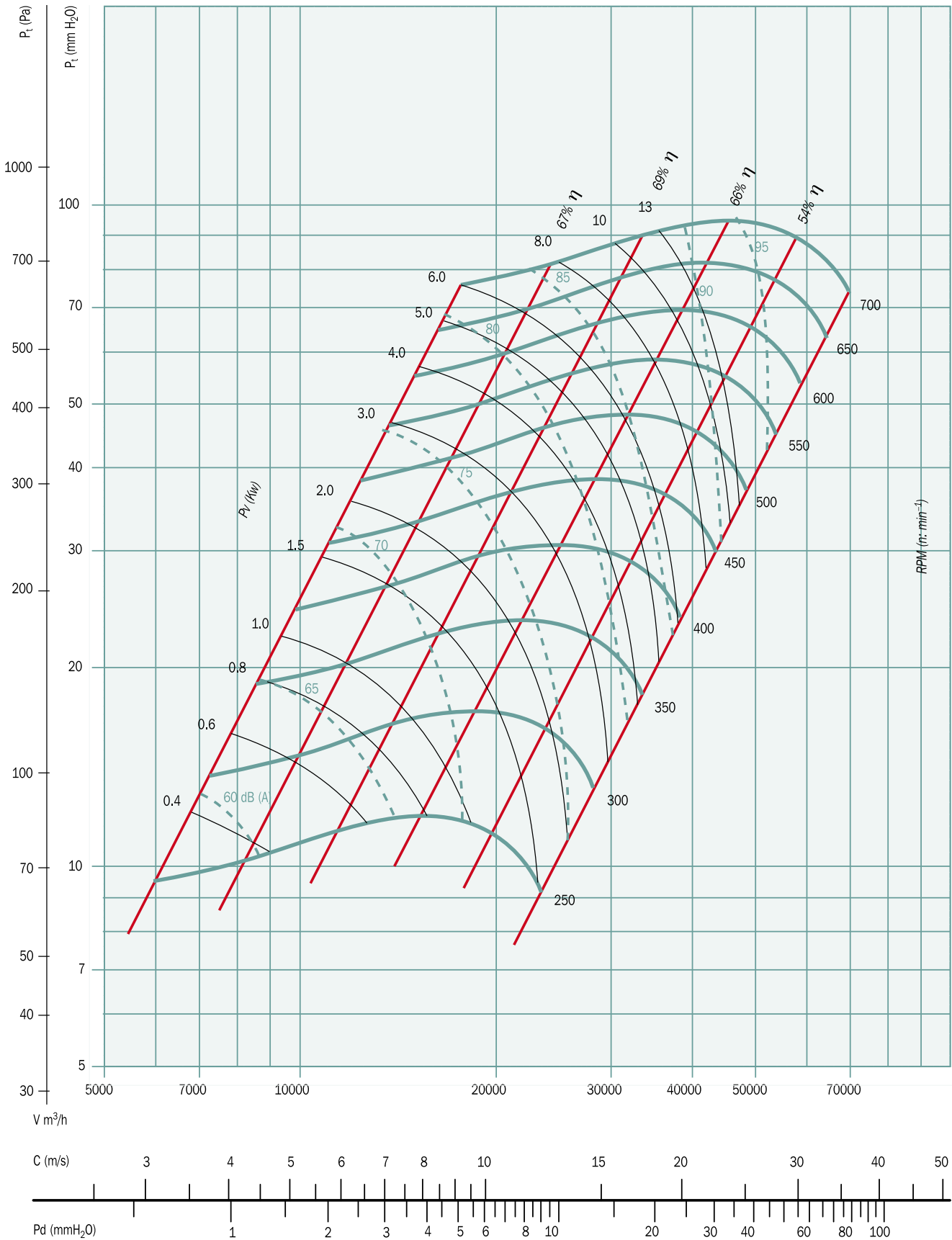

CURVAS CARACTERÍSTICAS / PERFORMANCE DATA / COURBES / KENNLINIEN

BPT / BPT BOX / BPT BOX HT / BPT BOX HT COMPACT 30-28

