

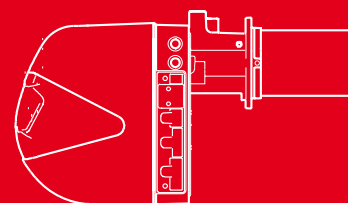

## RL/1 Series

One Stage Light Oil Burners

RL 34/1 MZ      107 ÷ 398 kW

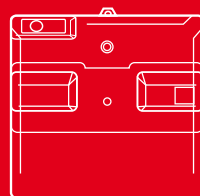

The RL/1 burners series covers a firing range from 107 to 398 kW, and it has been designed for use in low or medium temperature hot water boilers, hot air or steam boilers, diathermic oil boilers. All models are suitable for combustion of light oil and blend of light oil and biodiesel up to 5%. Optimisation of sound emissions is guaranteed by the special design of the air suction circuit. Special care has been paid to keeping overall dimensions compact and to easy servicing. The elevated fans and combustion head performance guarantees flexibility of use and excellent operation at all firing rates. A wide range of accessories guarantees elevated working flexibility.

## Technical Data

<b>MODEL</b>		<b>RL 34/1 MZ</b>	
Burner operation mode		One stage	
Modulation ratio to max. output		--	
Servomotor	type	--	
	run time	s	--
Heat output		kW	107 - 398
		Mcal/h	92 - 246
		Kg/h	9 - 34
Working temperature		°C min./max.	0/40
<b>FUEL/AIR DATA</b>			
Net calorific value		kWh/kg	11,8
		kcal/kg	10.200
Viscosity at 20°C		mm <sup>2</sup> /s (cSt)	4 ÷ 6
Pump	type	AN 57 C	
	output	kg/h at 12 bar	45
Atomised pressure		bar	12
Fuel temperature		Max. °C	50
Fan		type	centrifugal with forward curve blades
Air temperature		Max. °C	60
<b>ELECTRICAL DATA</b>			
Electrical supply		Ph/Hz/V	1/50-60/220-230~(±10%)
Auxiliary electrical supply		Ph/Hz/V	1/50-60/220-230~(±10%)
Control box		type	RM0
Total electrical power		kW	0,6
Auxiliary electrical power		kW	0,3
Protection level		IP	40
Motor electrical power		kW	0,3
Rated motor current		A	2,4
Motor start current		A	10
Motor protection level		IP	54
Ignition transformer	V1 - V2	230V - 2x12 kV	
	I1 - I2	0,2A - 30 mA	
Operation		intermittent (at least one stop every 24 h)	
<b>EMISSIONS</b>			
Sound pressure		dB(A)	70
Sound output		W	--
CO emission		mg/kWh	< 40
Grade of smoke indicator		N° Bach.	< 1
CxHy emission		mg/kWh	<10 (after the first 20 s.)
NOx emission		mg/kWh	< 185
<b>APPROVAL</b>			
Directive		2006/42/EC - 92/42/EC - 2014/30/UE - 2014/35/UE	
According to		EN 267	
Certification		CE-00360383/07	

Reference conditions:

Temperature: 20°C - Pressure: 1013,5 mbar - Altitude: 0 m a.s.l. - Noise measured at a distance of 1 meter.

Since the Company is constantly engaged in the production improvement, the aesthetic and dimensional features, the technical data, the equipment and the accessories can be changed. This document contains confidential and proprietary information of RIELLO S.p.A. Unless authorised, this information shall not be divulged, nor duplicated in whole or in part.

# Firing rate

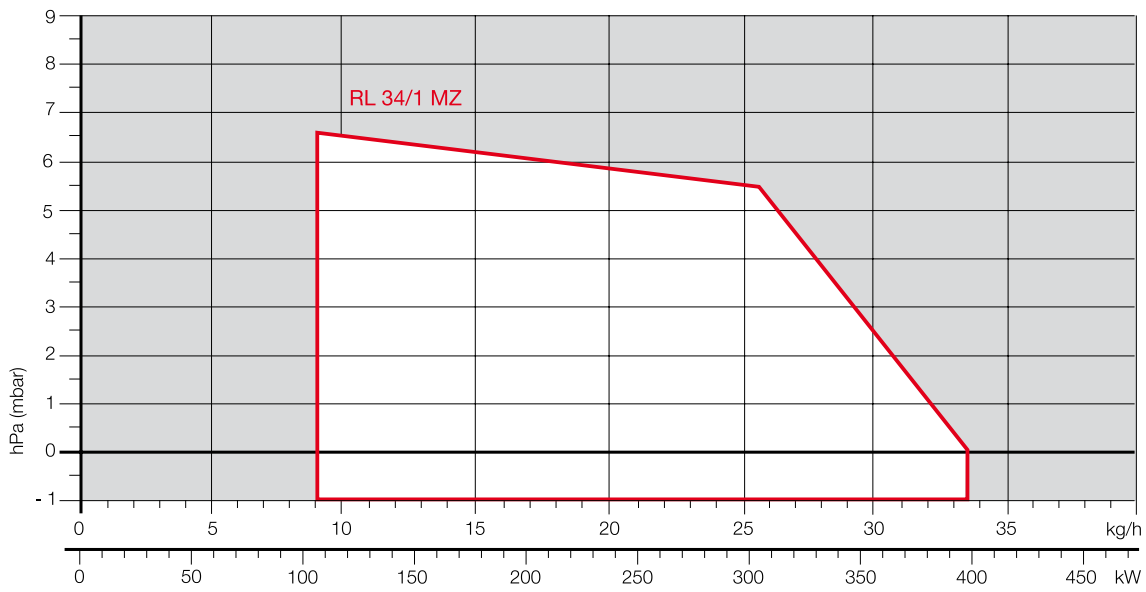

Useful working field for choosing the burner

Test conditions conforming to EN 267:

Temperature: 20°C

Pressure: 1013,5 mbar

Altitude: 0 m a.s.l.

# Fuel Supply

## HYDRAULIC CIRCUITS

The burner is fitted with a self-priming pump and two delivery valves along the oil line from the pump to the nozzles.

The pump does not need calibrating, as it is set in the factory at 12 bar; however, pressure level can be changed if necessary, by adjusting the regulator fitted on the pump.

The delivery valves control the passage from start-up to operating phase.

At the start, after pre-purging phase, the first delivery valve opens and the fuel is sprayed out through the first nozzle, igniting when it comes into contact with the spark; then the second delivery valve opens and the fuel is sprayed out through both nozzles.

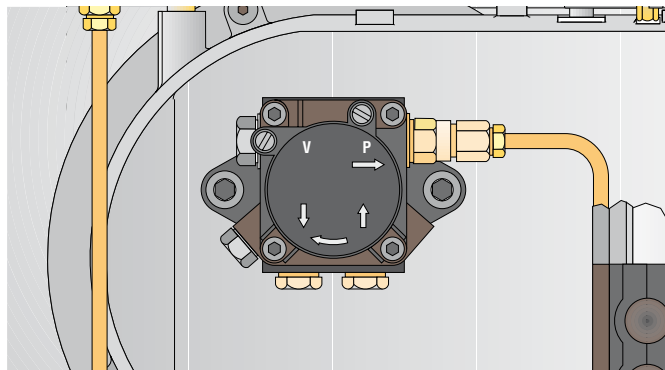

Example of self-priming pump of RL 34/1 MZ burner.

### Hydraulic layout of RL 34/1 MZ burner

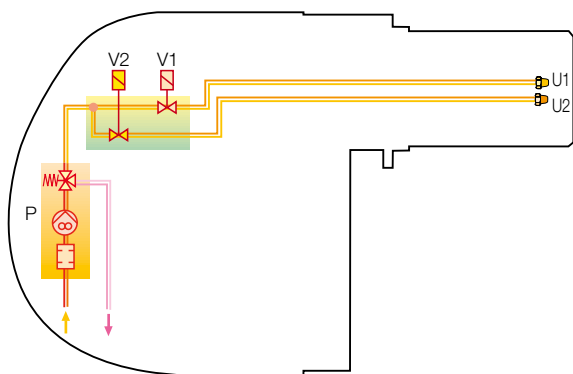

P	Pump with filter and pressure regulator
V1	1 <sup>st</sup> delivery valve
V2	2 <sup>nd</sup> delivery valve
U1	1 <sup>st</sup> nozzle
U2	2 <sup>nd</sup> nozzle

**DIMENSIONING OF THE FUEL SUPPLY LINES**

The fuel feed must be completed with the safety devices required by the local norms.

The table shows the choice of piping diameter for the various burners, depending on the difference in height between the burner and the tank and their distance.

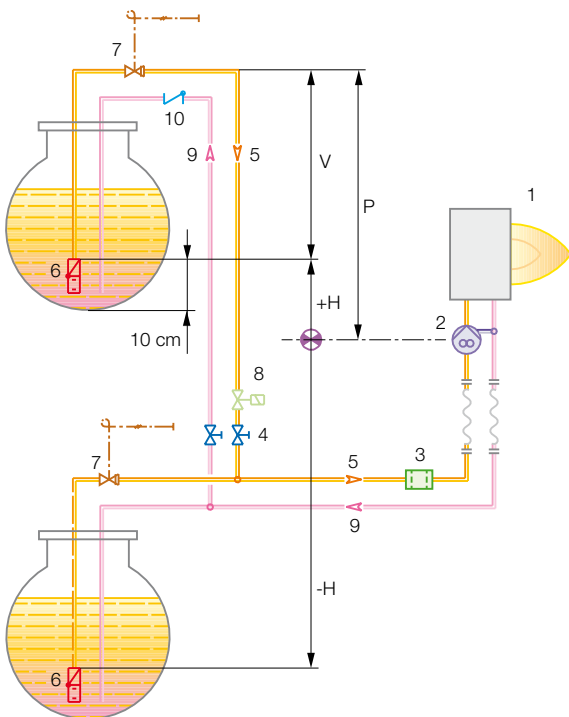

MAXIMUM EQUIVALENT LENGTH FOR THE PIPING L[m]

Model	RL 34/1 MZ		
	Ø10 mm	Ø12 mm	Ø14 mm
Diameter piping			
+H, -H (m)	L max (m)	L max (m)	L max (m)
+4,0	63	144	150
+3,0	55	127	150
+2,0	48	111	150
+1,5	44	102	150
+1,0	40	94	150
+0,5	37	86	150
0	33	78	150
-0,5	29	70	133
-1,0	25	82	118
-1,5	21	63	103
-2,0	17	45	88
-3,0	10	29	58
-4,0	4	12	28

H	Difference in height pump-foot valve
Ø	Internal pipe diameter
P	Height 10 m
V	Height 4 m
1	Burner
2	Burner pump
3	Filter
4	Manual shut off valve
5	Suction pipework
6	Bottom valve
7	Remote controlled rapid manual shut off valve (compulsory in Italy)
8	Type approved shut off solenoid valve (compulsory in Italy)
9	Return pipework
10	Check valve

With ring distribution oil systems, the feasible drawings and dimensioning are the responsibility of specialised engineering studios, who must check compatibility with the requirements and features of each single installation.

## Ventilation

In spite of the compact dimensions the ventilation circuit guarantees low noise levels with high performance pressure and air delivery.

The RL 34/1 MZ is realised with a structure made by an innovative technology based on a new fibreglass reinforced polyamide material, with high thermal and mechanical characteristics, instead of the traditional aluminium. This allows big advantages in terms of layout rationalisation, weight and dimensions reduction. In order to guarantee the correct exercise temperature for the internal burner components in every working conditions, the new structure includes an innovative patented cooling technology.

Between the burner front base and the reinforcing steel front plate, had been create an air cavity offering an high thermal insulation against the front boiler reflection heat, and to further improve the insulation efficiency the innovative **HCS (Housing Cooling System)** technology had been developed. Inside the front base cavity an air circulation is activated with continuous air volume refresh to obtain an active cooling system and avoid any heat transfer to the electrical component housing.



Example of HCS (Housing Cooling System) working concept.

## Combustion Head

RL/1 burners series has available different lengths of the combustion head. The choice depends on the thickness of the front panel and the type of boiler.

Depending on the type of generator, check that the penetration of the head into the combustion chamber is correct.

The internal position of the combustion head can easily be adjusted to the maximum defined output by adjusting a screw fixed to the flange.



Example of a RL 34/1 MZ burner combustion head.

### DIMENSIONS OF THE FLAME

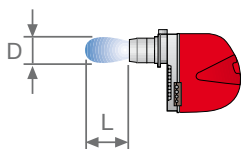

**Example:**  
 Burner thermal output = 500 kW;  
 L flame (m) = 1,3 m (medium value);  
 D flame (m) = 0,45 m (medium value)

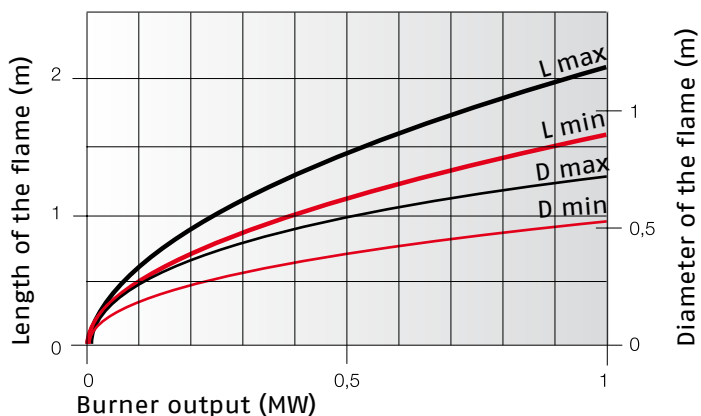

# Operation

## BURNER OPERATION MODE

RL/1 burners are one stage working.

On "one stage" operation, the burner adjusts output to the requested level, by varying between on-off phases (see picture A).

### "ONE STAGE" OPERATION

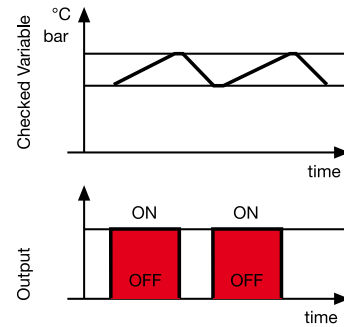

Picture A

All RL/1 burners are fitted with a new microprocessor control panel for the supervision during intermittent operation. For helping the commissioning and maintenance work, there are two main elements:

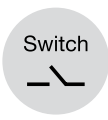
 The lock-out reset button is the central operating element for resetting the burner control and for activating / deactivating the diagnostic functions.

 The multi-color LED is the central indication element for visual diagnosis and interface diagnosis.

Both elements are located under the transparent cover of lock-out reset button, as showed below.



There are two diagnostic choices, for indication of operation and diagnosis of fault cause:

### VISUAL DIAGNOSIS





**INTERFACE DIAGNOSIS**

By the interface adapter and a PC with dedicated software or by a predisposed flue gas analyzer (see paragraph accessories).

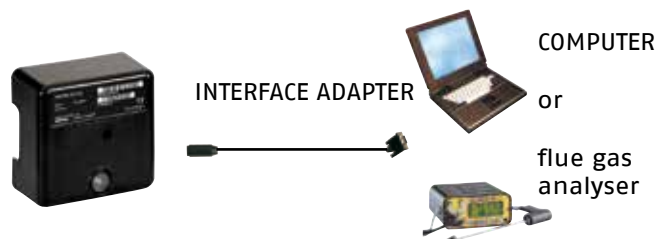

**INDICATION OF OPERATION**

In normal operation, the various status are indicated in the form of colour codes according to the table below. The interface diagnosis (with adapter) can be activated by pressing the lock-out button for > 3 seconds.

Color code table	
Operation status	Color code table
Stand-by	● ● ● ● ● ● ● ●
Pre-purging	● ● ● ● ● ● ● ●
Ignition phase	● ● ● ● ● ● ● ●
Flame OK	● ● ● ● ● ● ● ●
Poor flame	● ● ● ● ● ● ● ●
Undervoltage, built-in fuse	● ● ● ● ● ● ● ●
Fault, alarm	● ● ● ● ● ● ● ●
Extraneous light	● ● ● ● ● ● ● ●

● LED off

**DIAGNOSIS OF FAULT CAUSES**

After lock-out has occurred, the red signal lamp is steady on. In this status, the visual fault diagnosis according to the error code table can be activated by pressing the lock-out reset button for > 3 seconds.

The interface diagnosis (with adapter) can be activated by pressing again the lock-out button for > 3 seconds.

The flashing of red LED are a signal with this sequence:

(e.g. signal with n° 3 flashes – faulty air pressure monitor)



**ERROR CODE TABLE**

Possible cause of fault	Flash code
No establishment of flame at the end of safety time: - faulty or soiled fuel valves - faulty or soiled flame detector - poor adjustment of burner, no fuel - faulty ignition equipment	● 2x flashes
Faulty air pressure monitor	● 3x flashes
Extraneous light or simulation of flame on burner start up	● 4x flashes
Loss of flame during operation: - faulty or soiled fuel valves - faulty or soiled flame detector - poor adjustment of burner	● 7x flashes
Wiring error or internal fault	● 10x flashes

**START UP CYCLE**

RL 34/1 MZ

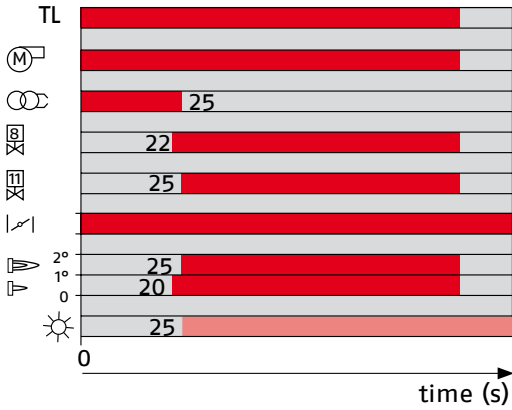

- 0s The burner begins the firing cycle: the motor and transformer are supplied. Pre-purging begins with the max air delivery.
- 22÷28s The 1st delivery valve opens and the fuel is ignited.
- 5s after firing The ignition transformer switches off. The 2nd delivery valve opens. This is the operating flame.

**Burner Wiring**

The RL/1 burner series has an easily accessible control panel for the electrical components housing and wiring. The RL 34/1 MZ model, thanks to the new structure concept, has a extremely clean electrical layout to optimise the commissioning and maintenance speed.

On this model the electrical connections are done by a Plug&Socket system, accessible from the external of the cover.

The electrical wiring of all RL/1 burner models are very easy to do following the wiring diagrams included in the instruction handbook.

Electrical connections must be made by qualified and skilled personnel, according to the local norms.

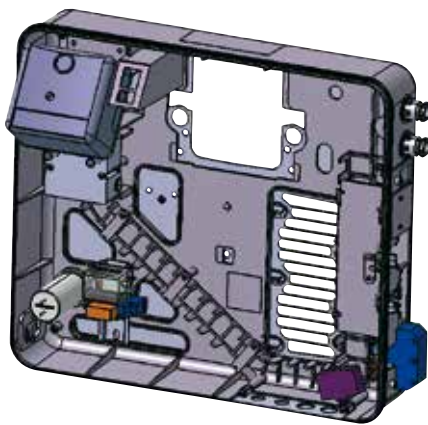

Example of electrical components housing and Plug&Socket system for electrical connection of RL 34/1 MZ.

The following table shows the supply lead sections and the type of fuse to be used.

MODEL	V	F (A)	L (mm <sup>2</sup> )
RL 34/1 MZ	230	T6	1,5

V = Electrical supply    F = Fuse    L = Lead section

## Emissions

The emission data has been measured at maximum output, according to EN 267 standard.  
 The NOx emissions of RL 34/1 MZ model are conforming to the class 2 of EN 267.

**NO<sub>2</sub> EMISSIONS**

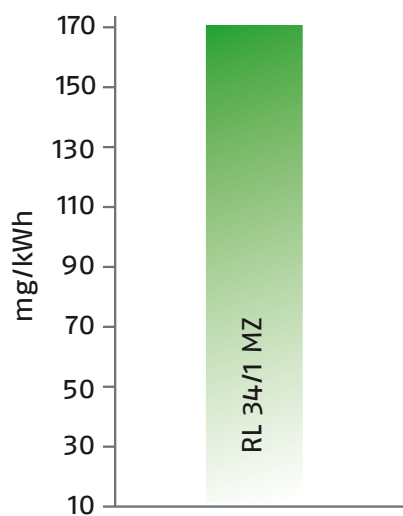

**CO EMISSIONS**

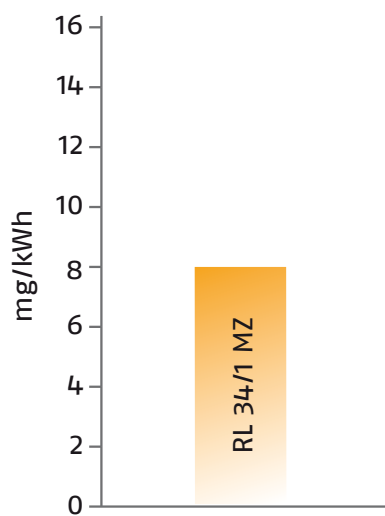

**NOISE EMISSIONS**

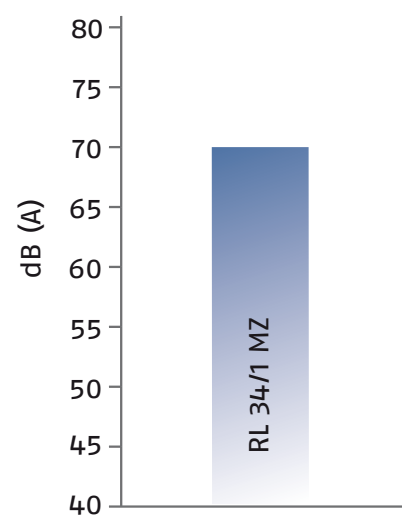

# Overall Dimensions (mm)

## BURNERS

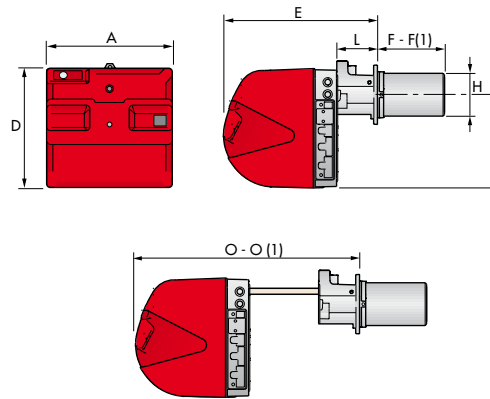

MODEL	A	D	E	F - F <sup>(1)</sup>	H	I	L	O - O <sup>(1)</sup>
RL 34/1 MZ	442	422	508	216 - 351	140	305	138	780 - 915

(1) dimension with extended head

## BURNER - BOILER MOUNTING FLANGE

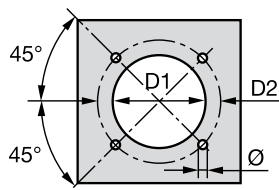

MODEL	D1	D2	Ø
RL 34/1 MZ	160	224	M8

## PACKAGING

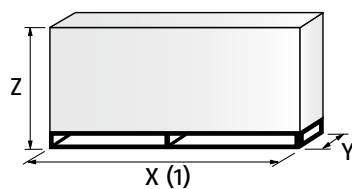

MODEL	X <sup>(1)</sup>	Y	Z	kg
RL 34/1 MZ	1000	485	500	32

(1) Length with short and extended head

## Installation Description

Installation, start up and maintenance must be carried out by qualified and skilled personnel. All operations must be performed in accordance with the technical handbook supplied with the burner.

### BURNER SETTING

All the burners have slide bars, for easier installation and maintenance.

After drilling the boilerplate, using the supplied gasket as a template, dismantle the blast tube from the burner and fix it to the boiler.

Adjust the combustion head.

Refit the burner casing to the slide bars.

Install the nozzles, choosing these on the basis of the maximum boiler output and following the diagrams included in the burner instruction handbook.

Check the position of the electrodes.

Close the burner, sliding it up to the flange, keeping it slightly raised to avoid the flame stability disk rubbing against the blast tube.



### HYDRAULIC AND ELECTRICAL CONNECTIONS AND START UP

The burners are supplied for connection to two pipes fuel supply system.

Connect the ends of the flexible pipes to the suction and return pipework using the supplied nipples.

Make the electrical connections to the burner following the wiring diagrams included in the instruction handbook.

Prime the pump by turning the motor.

On start up, check:

- Pressure pump
- Combustion quality, in terms of unburned substances and excess air.

# Burner Accessories

## Nozzles



The nozzles must be ordered separately. The following table shows the features and codes on the basis of the maximum required fuel output.

NOTE: each burner needs N°2 nozzles.

BURNER	NOZZLE TYPE	GPH	RATED OUTPUT (kg/h)			NOZZLE CODE
			at 10 bar	at 12 bar	at 14 bar	
RL 34/1 MZ	60°A	1,00	4,1	4,5	4,9	3042078
	60°A	1,25	4,7	5,2	5,6	3042094
	60°A	1,50	5,7	6,3	6,8	3042108
	60°A	1,75	6,7	7,3	7,9	3042114
	60°A	2,00	7,7	8,5	9,2	3042124
	60°A	2,50	9,6	10,6	11,5	3042144
	60°A	3,00	11,5	12,7	13,8	3042148
	60°A	3,50	13,5	14,8	16,1	3042164
	60°A	4,00	15,4	17	18,4	3042174

## Extended heads

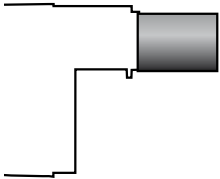

“Standard head” burners can be transformed into “extended head” versions, by using the special kit. The kit available, giving the original and the extended lengths, is listed below.

BURNER	'STANDARD' HEAD LENGTH (mm)	'EXTENDED' HEAD LENGTH (mm)	KIT CODE
RL 34/1 MZ	216	351	3010426

## Spacer kit



If burner head penetration into the combustion chamber needs reducing, varying thickness spacers are available, as given in the following table:

BURNER	SPACER THICKNESS S (mm)	KIT CODE
RL 34/1 MZ	110	3010095

## Sound proofing box

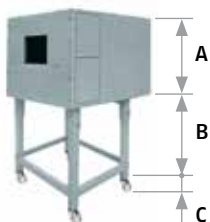

If noise emission needs reducing even further, sound-proofing boxes are available.

In case of generator heights, where a lower dimension “B” is required, ask for the Box Support Kit code 20065135.

BURNER	BOX TYPE	A (mm)	B (mm) min-max	C (mm)	[dB(A)] (*)	BOX CODE
RL 34/1 MZ	C1/3	650	372 - 980	110	10	3010403

(\*) Average noise reduction according to EN 15036-1 standard

**Degasing unit**



With single pipe systems, you can find air in the oil sucked by the pump that comes from the oil itself due to negative pressure or to a faulty seal. To solve this problem, we recommend fitting a degassing unit near the burner. Two versions are available with or without filter:

BURNER	FILTER	KIT CODE
RL 34/1 MZ	With filter	3010055
RL 34/1 MZ	Without filter	3010054

**Connection flange kit**

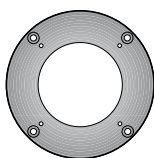

A kit is available for use where the burner opening on the boiler is of excessive diameter.

BURNER	KIT CODE
RL 34/1 MZ	3010138

**Volt free contact kit**



A volt free contact kit is available for installation onto the burner. It can be used for a remote interface between burner operating signals. Every burner can be equipped with a single kit to remote the flame presence signal and the burner lockout indication.

BURNER	KIT CODE
RL 34/1 MZ	3010419

**PC interface kit**



To connect the control box to a personal computer for the transmission of operation, fault signals and detailed service information, an interface adapter with PC software are available.

BURNER	KIT CODE
RL 34/1 MZ	3002719

**Ground fault interrupter kit**



A "Ground fault interrupter kit" is available as a safety device for electrical system fault.

BURNER	KIT CODE
RL 34/1 MZ	3010448

**Post-ventilation kit**

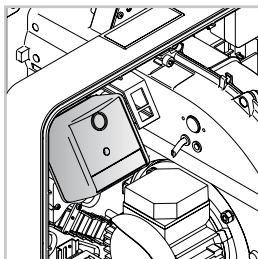

To have 20 s ventilation after opening of thermostats chain, a special kit is available.

BURNER	KIT CODE
RL 34/1 MZ	3010453

**Hours counter kit**

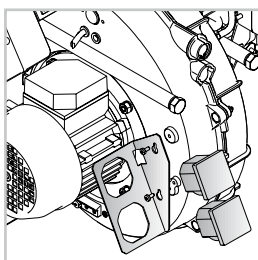

To measure the burner working time a hours counter kit is available.

BURNER	KIT CODE
RL 34/1 MZ	3010450

**Protection kit (electromagnetic interferences)**

When the burner is installed in a room particularly subject to electromagnetic interference (signals emitted over 10 V/m) due for example to INVERTER presence or in systems where the lengths of the thermostat connections is over 20 meters, this specific protection kit is available as an interface between the thermostatic controls and the burner.

BURNER	KIT CODE
All models	3010386

**Head kit for "reverse flame chamber"**



In certain cases, the use of the burner on reverse flame boilers can be improved by using an additional cylinder.

BURNER	STANDARD HEAD LENGTH WITH CYLINDER (mm)	EXTENDED HEAD LENGTH WITH CYLINDER (mm)	KIT CODE
RL 34/1	319	429	3010178



# Specification

## DESIGNATION OF SERIES

A specific index guides your choice of burner. Below is a clear and detailed specification description of the product.

Series: R										
Fuel:		S	Natural Gas							
		SP	LPG							
		L	Light oil							
		LS	Light oil/Methane							
		N	Heavy oil							
Size										
Setting:		/1	Single stage							
		...	Two stage							
		/M	Modulating							
Emission:		...	Class 1 EN267 - EN676							
		MZ	Class 2 EN267 - EN676							
		BLU	Class 3 EN267 - EN676							
		MX	Class 1 EN267 Class 3 EN676							
Head length:		TC	standard head							
		TL	extended head							
Flame control system:		FS1	Standard (1 stop every 24 h)							
		FS2	Continuous working (1 stop every 72 h)							
Electrical supply to the system:										
		1/230/50	1/230V/50Hz							
		1/220-230/50-60	1/220-230V/50-60Hz							
		3/230/50	3/230V/50Hz							
		3/400/50	3N/400V/50Hz							
		3/230-400/50	3/230V/50Hz - 3N/400V/50Hz							
		3/220/60	3/220V/60Hz							
		3/380/60	3N/380V/60Hz							
		3/220-380/60	3/220V/60Hz - 3N/380V/60Hz							
		3/220-230/50-60	3/220-230V/50-60Hz							
		3/220-400/50-60	3/380-400V/50-60Hz							
Auxiliary voltage:		230/50-60	230V/50-60Hz							
		220-230/50-60	220-230V/50-60Hz							
		110/50-60	110V/50-60Hz							
ID:		Differential switch								

R	L	34	/1	MZ	TC	FS1	1/230/50	230/50-60	
BASIC DESIGNATION					EXTENDED DESIGNATION				

**AVAILABLE BURNER MODELS**

RL 34/1 MZ	TC	FS1	1/230/50-60	230/50-60
RL 34/1 MZ	TL	FS1	1/230/50-60	230/50-60

Other versions are available on request.

## PRODUCT SPECIFICATION

Monoblock forced draught oil burner with one stage operation, fully automatic, made up of:

- Air suction circuit with sound proofing material
- High performance fan with forward curve blades
- Air damper for air setting
- Starting motor at 2800 rpm, single-phase, 230V / 50-60Hz
- Combustion head, that can be set on the basis of required output, fitted with:
  - stainless steel end cone, resistant to corrosion and high temperatures
  - ignition electrodes
  - flame stability disk
- Fan pressure test point
- Gears pump for high pressure fuel supply, fitted with:
  - filter
  - pressure regulator
  - connections for installing a pressure gauge and vacuumeter
  - internal by-pass for single pipe installation
- Valve unit with a double oil delivery valve on the output circuit
- Photocell for flame detection
- Microprocessor-based burner safety control box, with diagnostic function
- Plugs and socket for electrical connections, accessible from the external of the cover
- Flame inspection window
- Slide bars for easier installation and maintenance
- Protection filter against radio interference
- IP X0D (IP 40) electric protection level.

Conforming to:

- 2014/30 UE Directive (electromagnetic compatibility)
- 2014/35 UE Directive (low voltage)
- 2006/42 EC Directive (machine)
- EN 267 (liquid fuel burners)

Standard equipment:

- 2 flexible pipes for connection to the oil supply network
- 2 gaskets for the flexible pipes
- 2 nipples for connection to the pump
- 1 thermal screen
- 2 slide bar extensions (for model with long blast tube)
- 4 screws for fixing the burner flange to the boiler
- 1 7pin plug for electrical connection
- Instruction handbook for installation, use and maintenance
- Spare parts catalogue.

Available accessories to be ordered separately:

- extended heads
- spacer kit
- sound-proofing box
- degasing unit
- connection flange kit
- volt free contact kit
- PC interface kit
- ground fault interrupter kit
- post-ventilation kit
- hours counter kit
- protection kit (electromagnetic interfaces)
- head kit for "reverse flame chamber"

# Riello Burners a world of experience in every burner we sell.



[ 1 ]



[ 2 ]

Across the world, Riello sets the standard in reliable and high efficiency burner technology.

With burner capacity from 5 kW to 48 MW, Riello gas, oil, dual fuel and Low Nox burners deliver unbeatable performance across the full range of residential and commercial heating applications, as well as in industrial processes.

With headquarter in Legnago, Italy, Riello has been manufacturing premium quality burners for over 90 year. The manufacturing plant is equipped with the most innovative systems of assembling lines and modern manufacturing cells for a quick and flexible response to the market.

Besides, the Riello Combustion Research Centre, located in Angiari, Italy, represents one of the most modern facility in Europe and one of the most advanced in the world for the development of the combustion technology.

Today, the company's presence on worldwide markets is distinguished by a well-constructed and efficient sales network, alongside many important Training Centres located in various countries to meet its customers' needs. Riello has 13 operational branches abroad (in Europe, America and Asia), with customers in over 60 countries.

[ 1 ] BURNERS PRODUCTION PLANT  
S. PIETRO, LEGNAGO (VERONA) - ITALIA

[ 2 ] HEADQUARTER BURNERS DIVISION  
S. PIETRO, LEGNAGO (VERONA) - ITALIA

RIELLO S.p.A. - 37045 Legnago (VR) - Italy  
tel. +39 0442 630111 - fax: +39 0442 21980  
[www.riello.com](http://www.riello.com)

Since the Company is constantly engaged in the production improvement, the aesthetic and dimensional features, the technical data, the equipment and the accessories can be changed. This document contains confidential and proprietary information of RIELLO S.p.A. Unless authorised, this information shall not be divulged, nor duplicated in whole or in part.

# RIELLO