

DISC VALVES

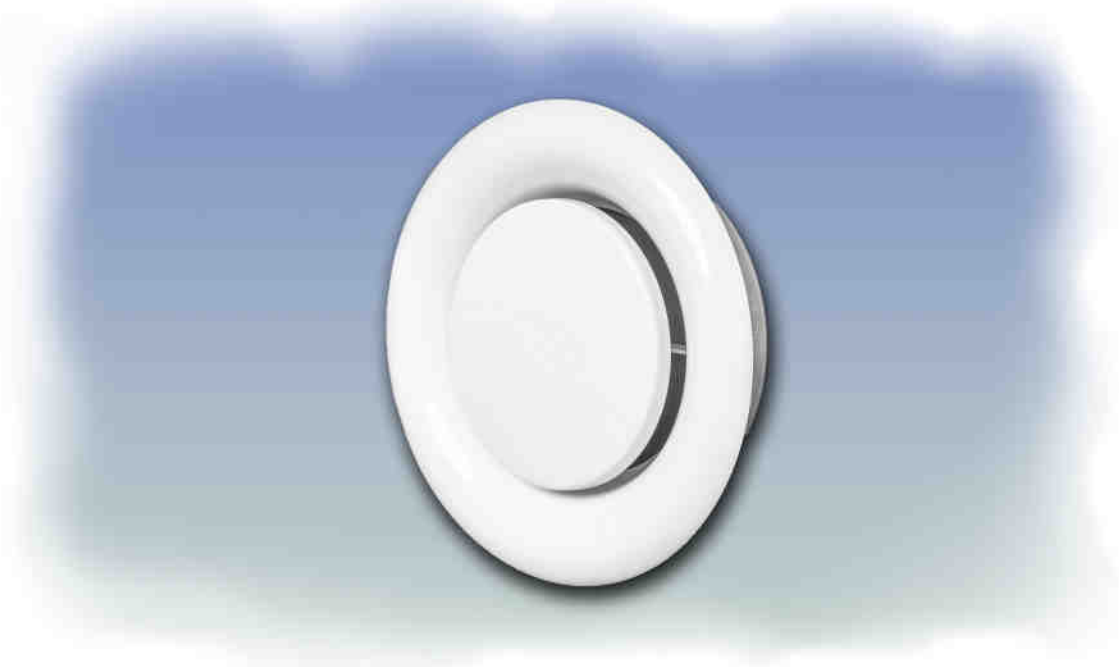

EDV

Exhaust Air Disc Valve



intertek

FAISAL JASSIM INDUSTRIES (L.L.C.)

P.O. Box 1871 Plot # 598-1152
Dubai Investment Park - Dubai, UAE

Tel. # 04 810-5105

Fax. # 04 810-5106

Email: fjtrdg@emirates.net.ae

Website: www.faisaljassim.ae

EXHAUST AIR DISC VALVES (EDV)



Exhaust Air Disc Valves (EMDV)

Products Features:

- Circular exhaust air valves.
- Steel construction.
- Center core adjustable by screw and nut for air volume control.
- The outer body is fitted with a foam - rubber gasket to form an airtight seal with the mounting ring.

Standard Finish:

White powder coated. Other colors are available upon request.

Fixing:

Galvanized steel mounting ring with screw holes.

Available Sizes:

ØN	N	D	F
100	96	75	138
125	123	100	164
150	148	120	202
200	198	158	248

ØN = Normal Size

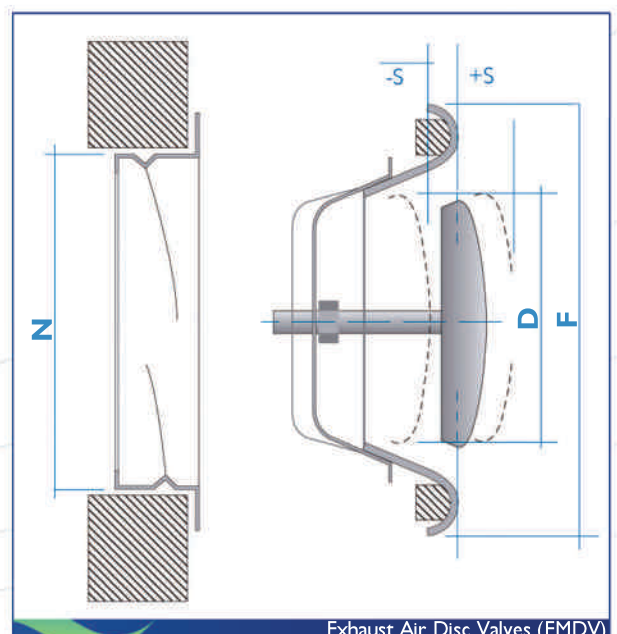

Exhaust Air Disc Valves (EMDV)

SELECTION CHART

Circular Air Valves EDV

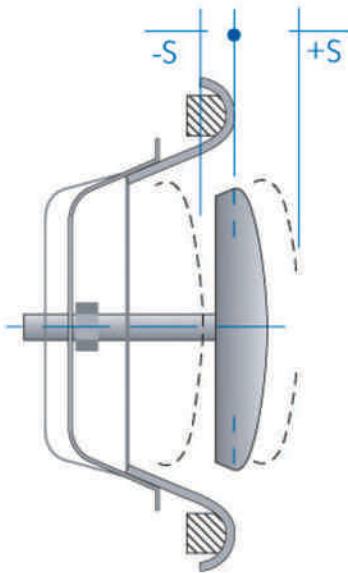

Exhaust air valves.
Steel construction.

NOMINAL SIZES (mm)				AIR FLOW, (m ³ /h)									
100	125	150	200		20	40	60	80	100	150	200	300	
				Pa	90								
				NR	-								
-9				Pa	45	170							
-9				NR	-	20							
-6	-12			Pa	20	80	200	300					
-6	-12			NR	-	12	25	28					
-3			-20	Pa	10	50	120	200					
-3			-20	NR	-	-	17	26					
	-6			Pa		30	70	120	200				
	-6			NR		-	12	20	28				
6				Pa	20	40	80	130					
6				NR		-	-	15	22				
	0		15	Pa		15	30	60	80	200			
	0		15	NR		-	-	11	18	30			
12	6			Pa		10	20	40	60	150			
12	6			NR		-	-	-	13	27			
		0-		Pa			15	25	40	90	170		
		0-		NR			-	-	9	21	30		
	12	6		Pa				15	25	60	100	220	
	12	6		NR				-	-	15	25	31	
		12	0	Pa					15	30	60	150	
		12	0	NR					-	10	18	30	

Exhaust Air Disc Valve (EMDV)